



S3079



S3080

S3079 & S3080 ADJUSTABLE BALL VALVE LOCKOUT DEVICES

S3079 - XL Valves from 2in (51mm) to 8in (20cm)

S3080 - Valves from 0.5in (13mm) to 2in (50mm)

Easy-to-use, adjustable design prevents accidental activation of a closed ball valve

The Master Lock S3079 and S3080 are designed to help comply with OSHA requirements and provide peace of mind during lockout involving ball valves. By encompassing the ball valve handle, these easy-to-use, adjustable lockout devices secure against unauthorized or premature valve activation and will enable lockout by multiple workers at each lockout point.

- Durable, lightweight thermoplastic material is chemical resistant
- Adjustable design accommodates multiple valve sizes
- Performs effectively in extreme environments
- Locking holes are compatible with all Master Lock safety padlocks

S3079 XL Ball Valve Lockout Device, 51mm - 20cm

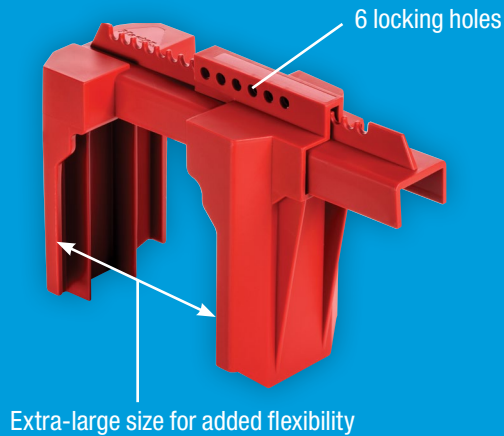

S3080 Ball Valve Lockout Device, 13-50mm

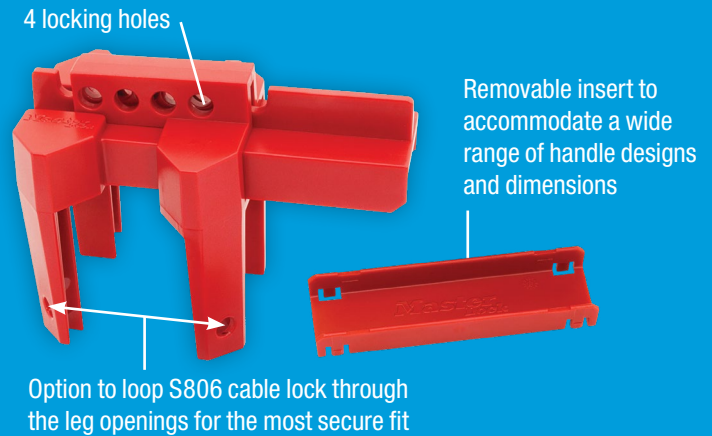

S3079 Specifications

Product Number	S3079
Description	XL Adjustable Ball Valve Lockout
Valve Size	2in (51mm) to 7.8in (20cm)
Weight	1.14lbs (520gr)
Product Dimensions	4.5in (11.5cm) W x 28.6in (21.8cm) H x 12.2in (30.9cm) L
Material Used	Polypropylene
Color	Red
Temperature Range	(-40°C/-40°F to 65°C/149°F)
Chemical Resistance	Resistant to common industrial chemicals, including Methylene Chloride, Sodium Hypochlorite, Polydimethylsiloxane, Sodium Metasilicate, Diethyl Ether, Acetic Acid, Methanol, N-Hexane, Naphtha, Toluene
Locking Features	Secure with padlock
UV Resistance	UL 746C - F2
Compliance	REACH, ATEX
Packaging	Commercial Bagged
Master Carton Quantity	6

S3080 Specifications

Product Number	S3080
Description	Adjustable Ball Valve Lockout
Valve Size	0.5in (12.7mm) to 2in (50.8mm)
Weight	0.34lbs (156g)
Product Dimensions	3in (76.9mm) W x 4in (10.4cm) H x 5.25in (13.4cm) L
Material Used	Polycarbonate and PBT
Color	Red
Temperature Range	(-40°C/-40°F to 93°C/200°F)
Chemical Resistance	Resistant to common industrial chemicals, including Methylene Chloride, Sodium Hypochlorite, Polydimethylsiloxane, Sodium Metasilicate, Diethyl Ether, Acetic Acid, Methanol, N-Hexane, Naphtha, Toluene
Locking Features	Secure with padlock or with S806 cable lockout for most secure fit
UV Resistance	UL 746C - F2
Compliance	REACH
Packaging	Commercial Bagged
Master Carton Quantity	6

Visit masterlocksafety.com for all Safety Lockout products



www.masterlock.com

Master Lock Company LLC, Milwaukee, WI 53154 U.S.A. | 800-308-9244
Master Lock Canada, Mississauga, Ontario L5L 5Z9 Canada
© 2023 Master Lock Company | All Rights Reserved.



Contact Your Martin Sales Rep
or call 800.828.8116.
www.martinsupply.com

See How
it Works

