

Bolts, Nuts & Washers









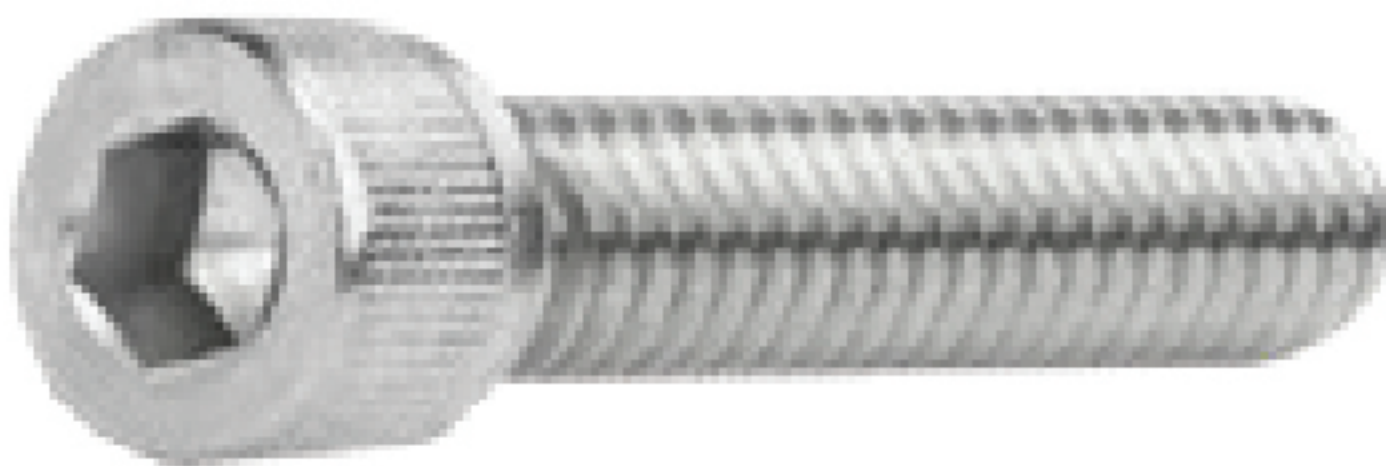
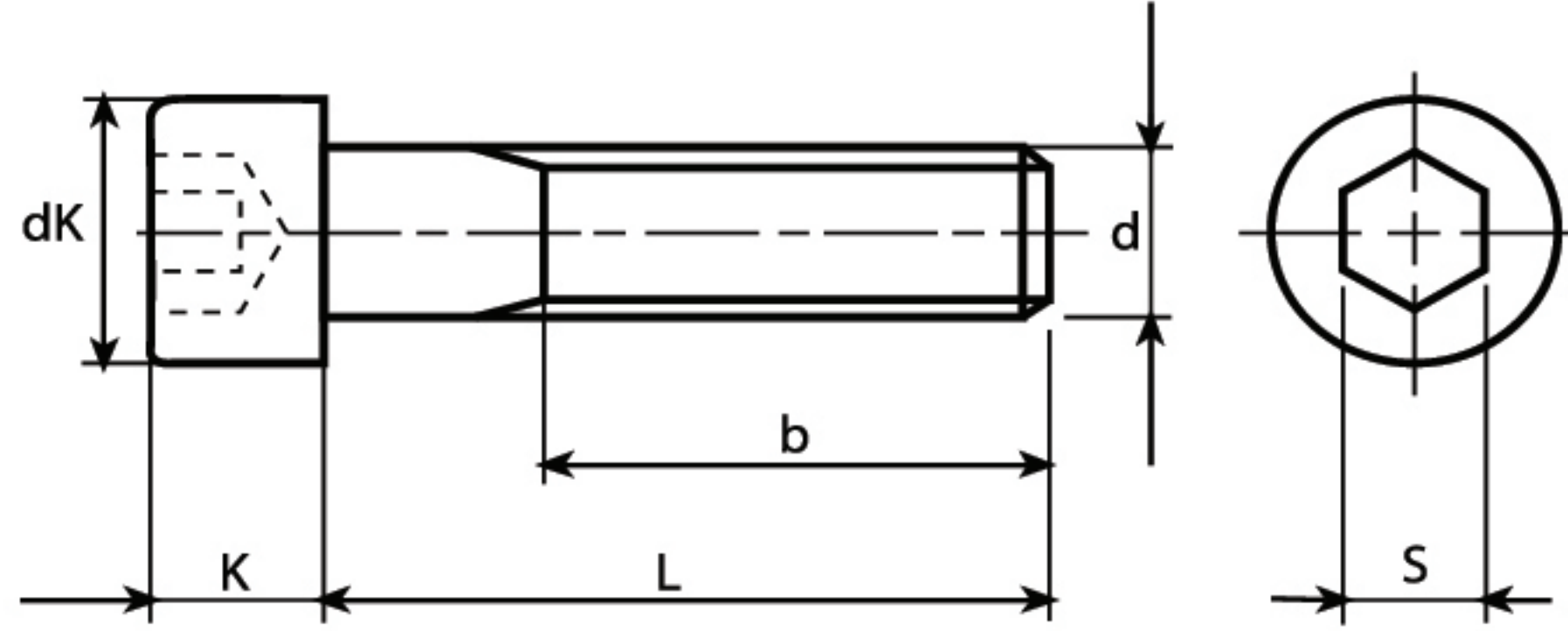

Learn More
About Martin's
Fastening
Solutions

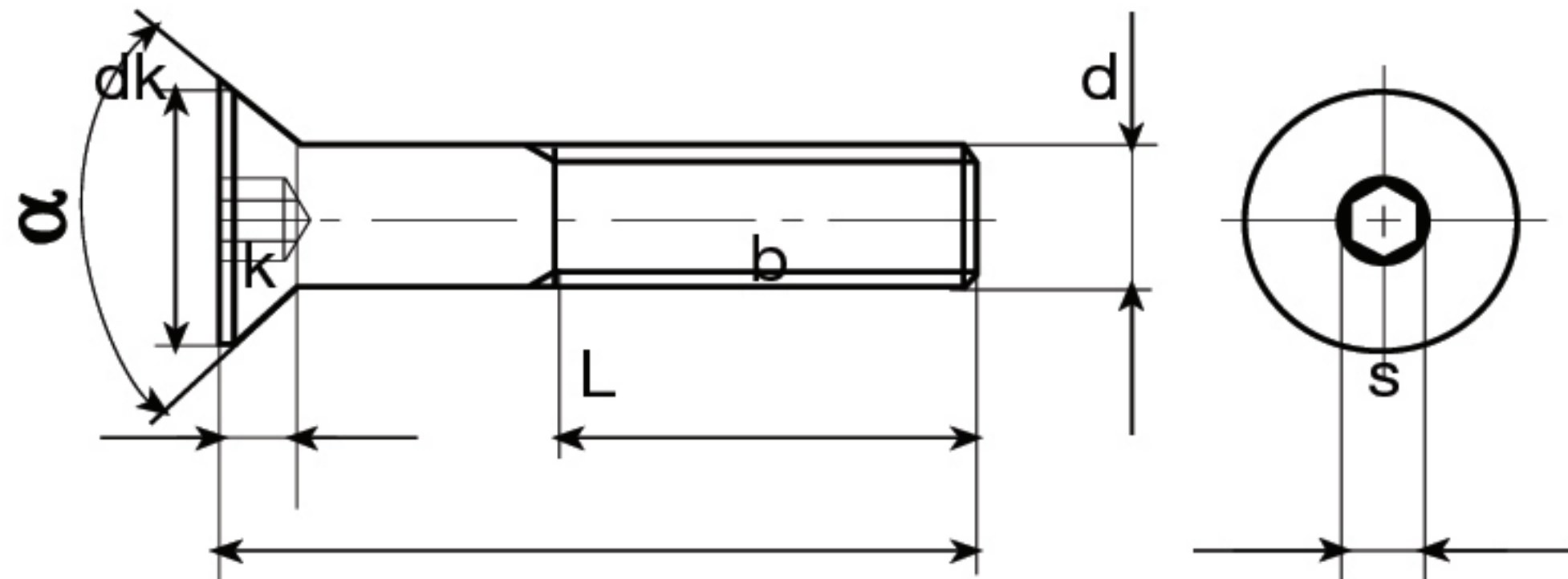

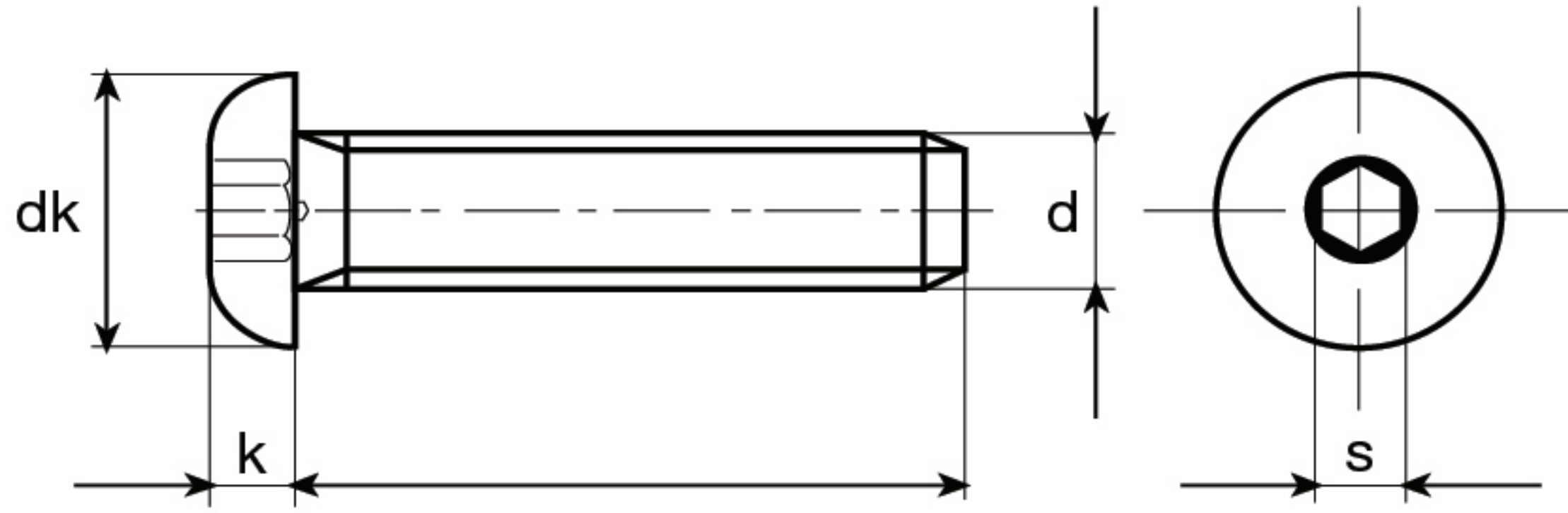

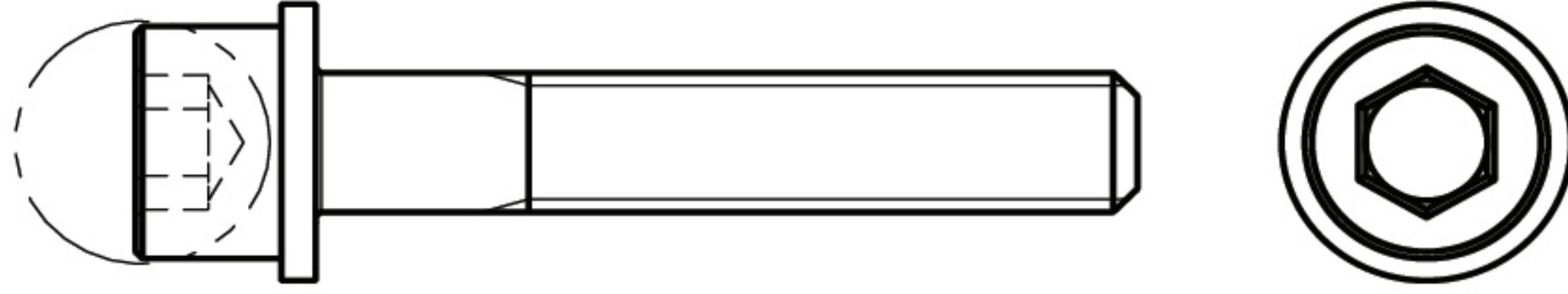
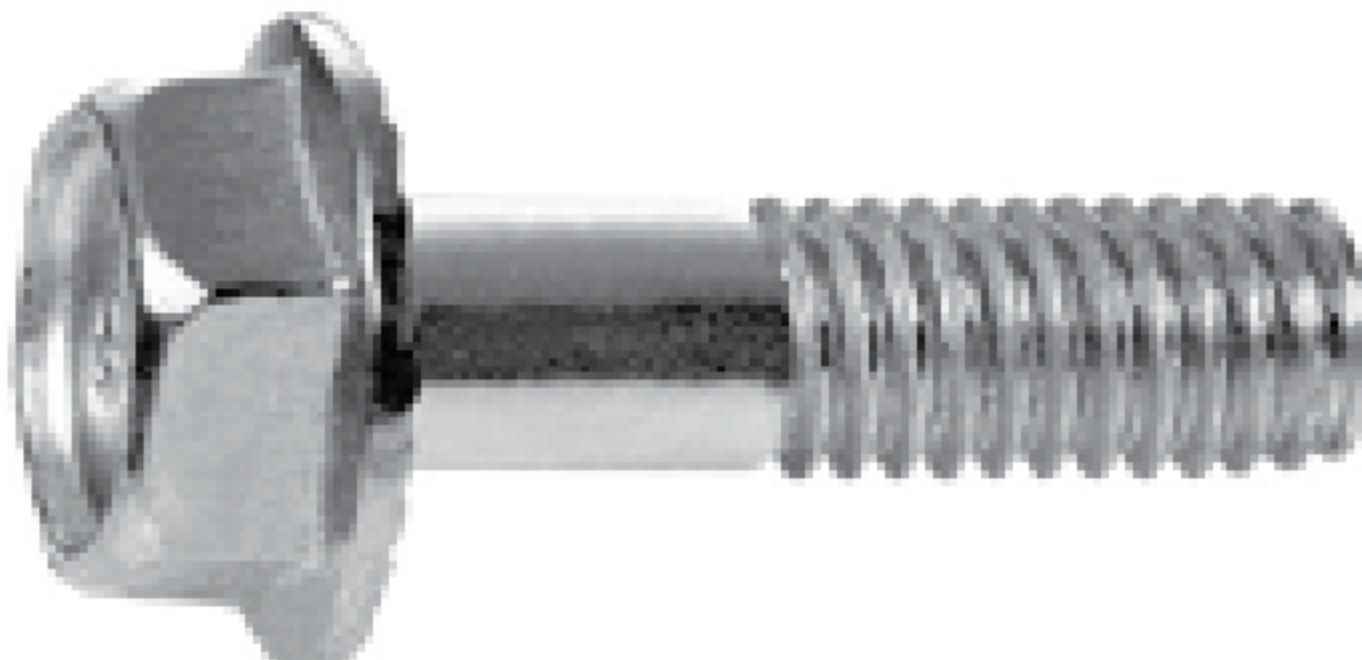
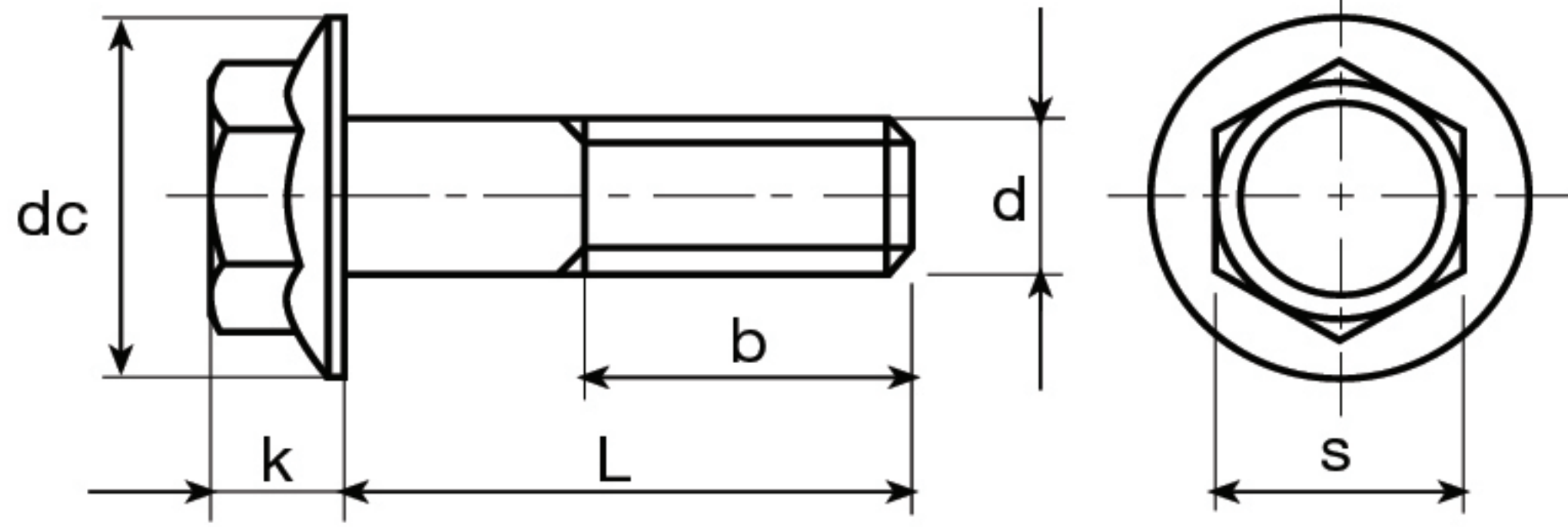
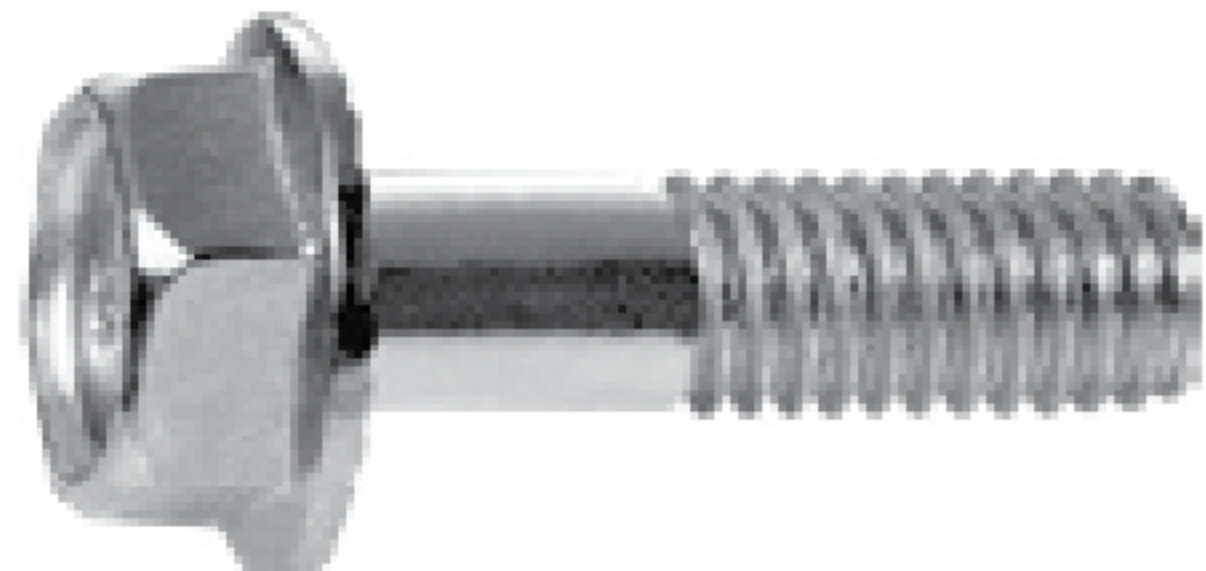
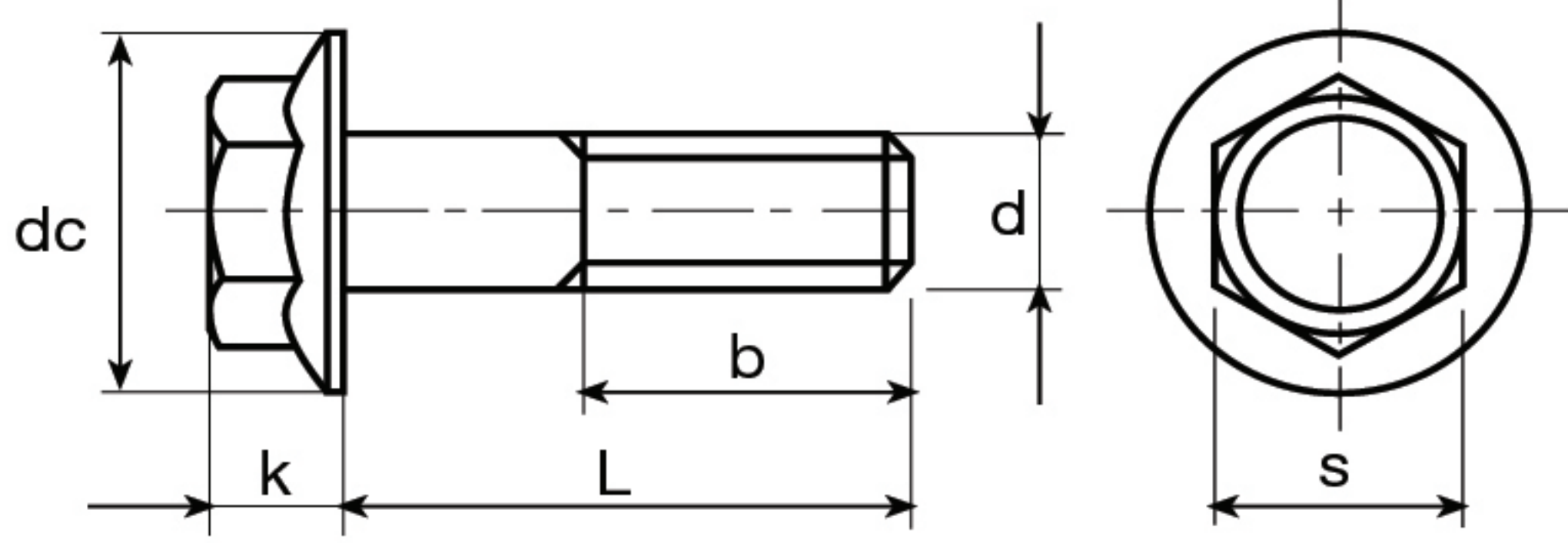

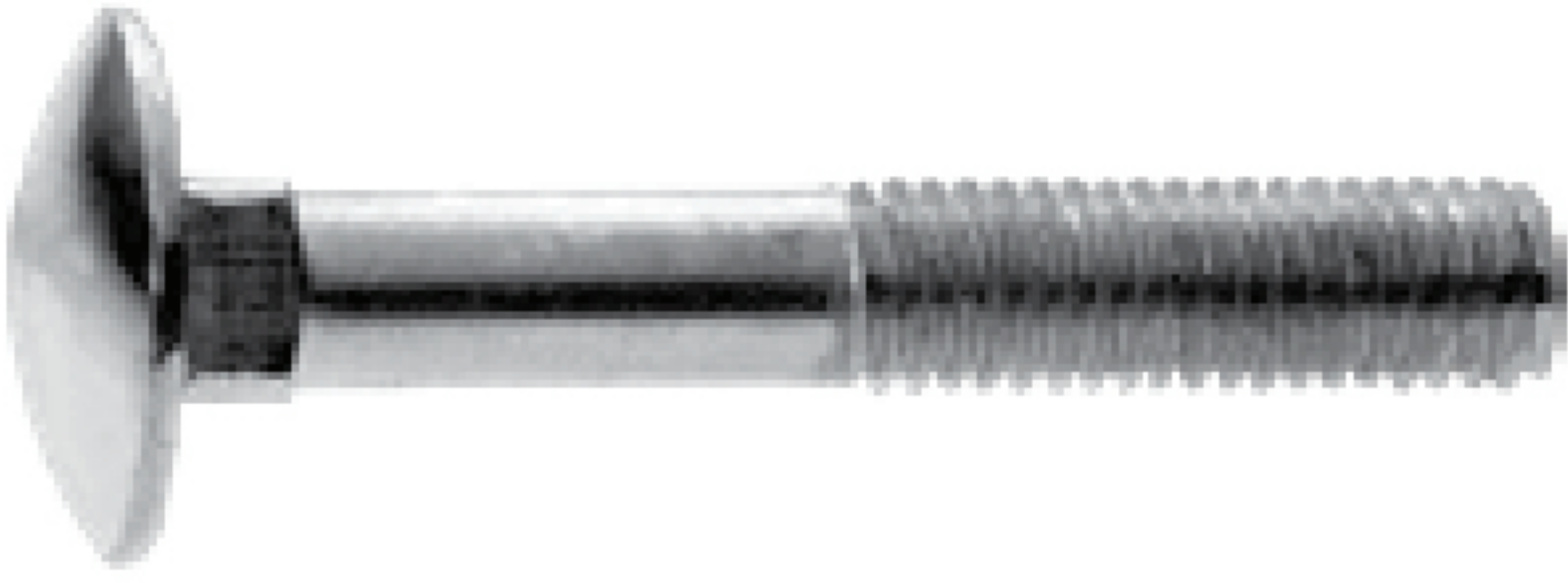
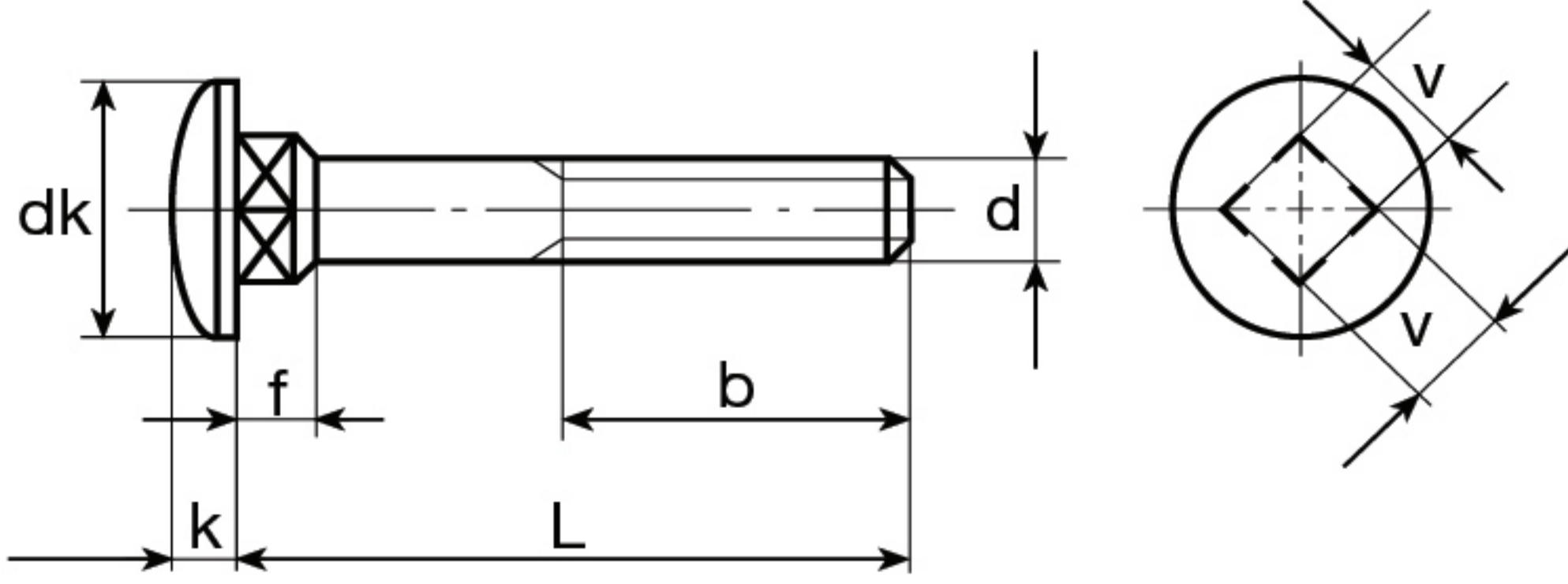
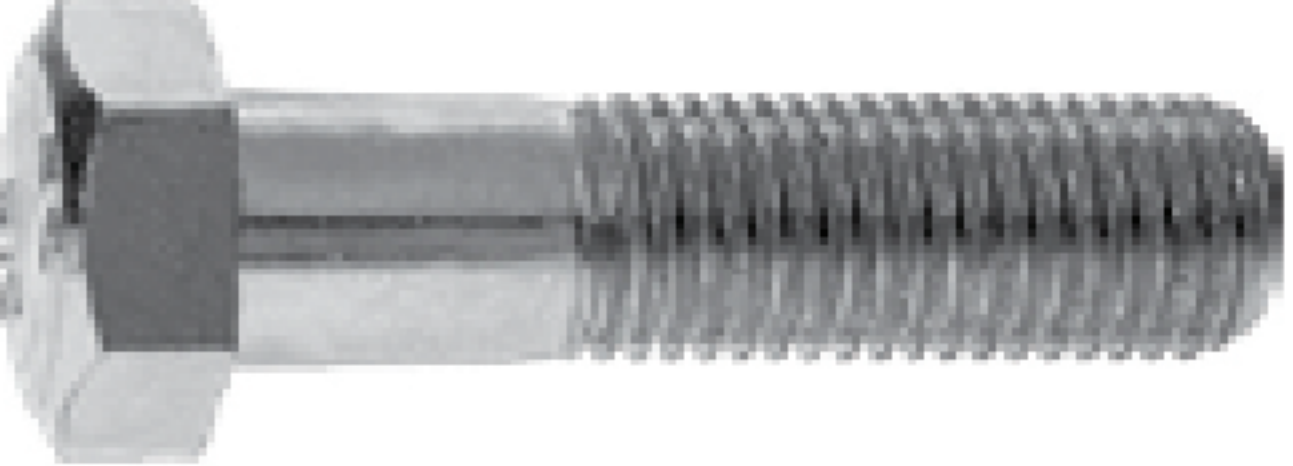
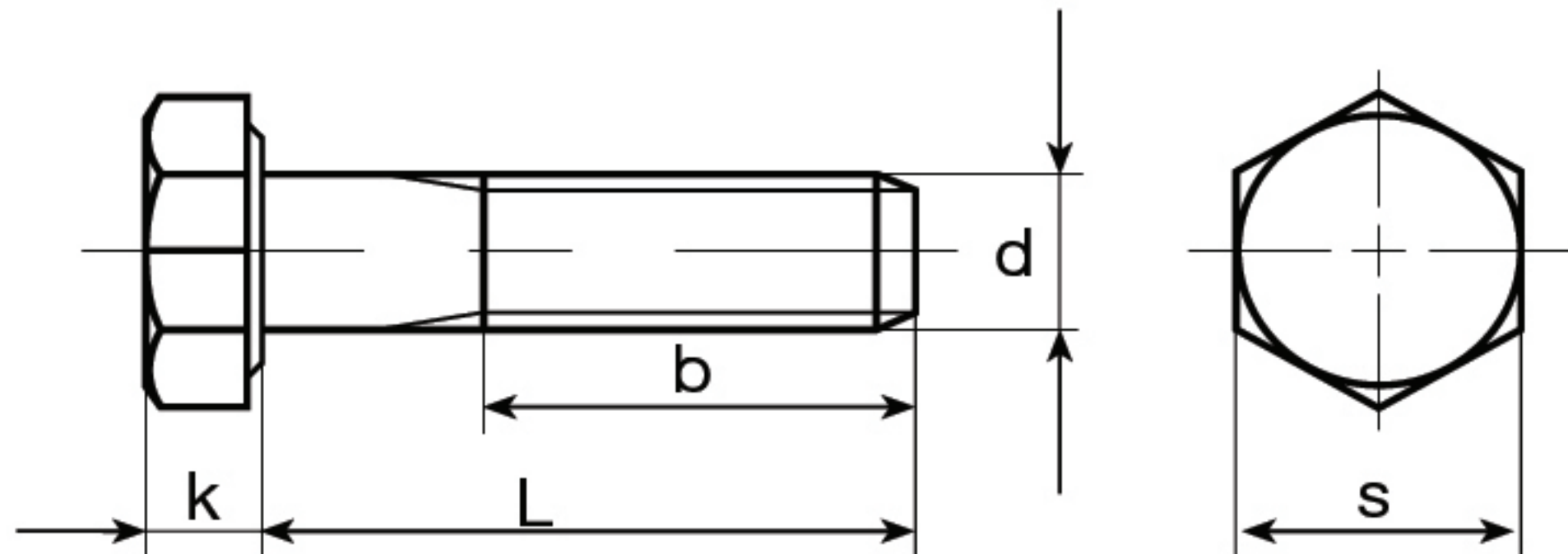
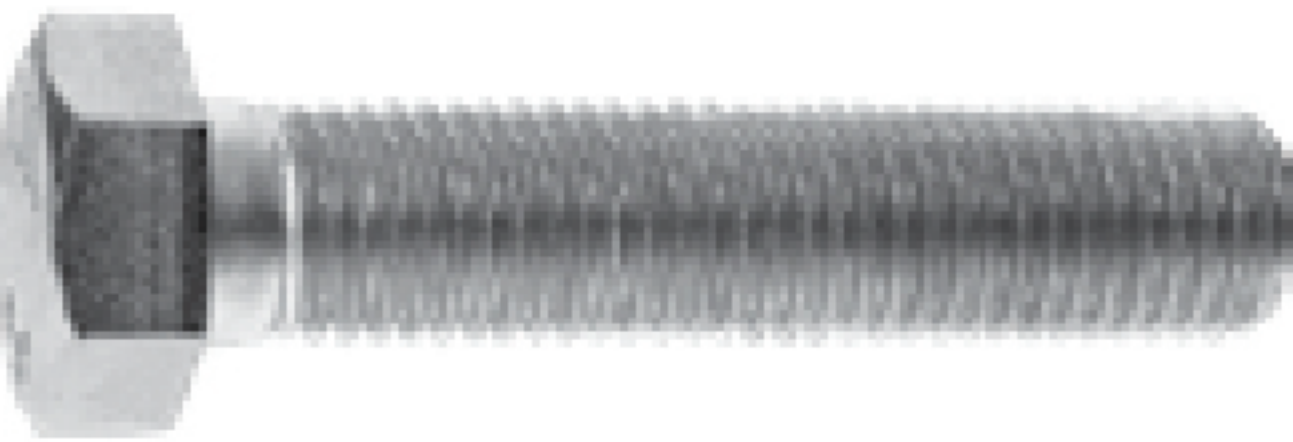
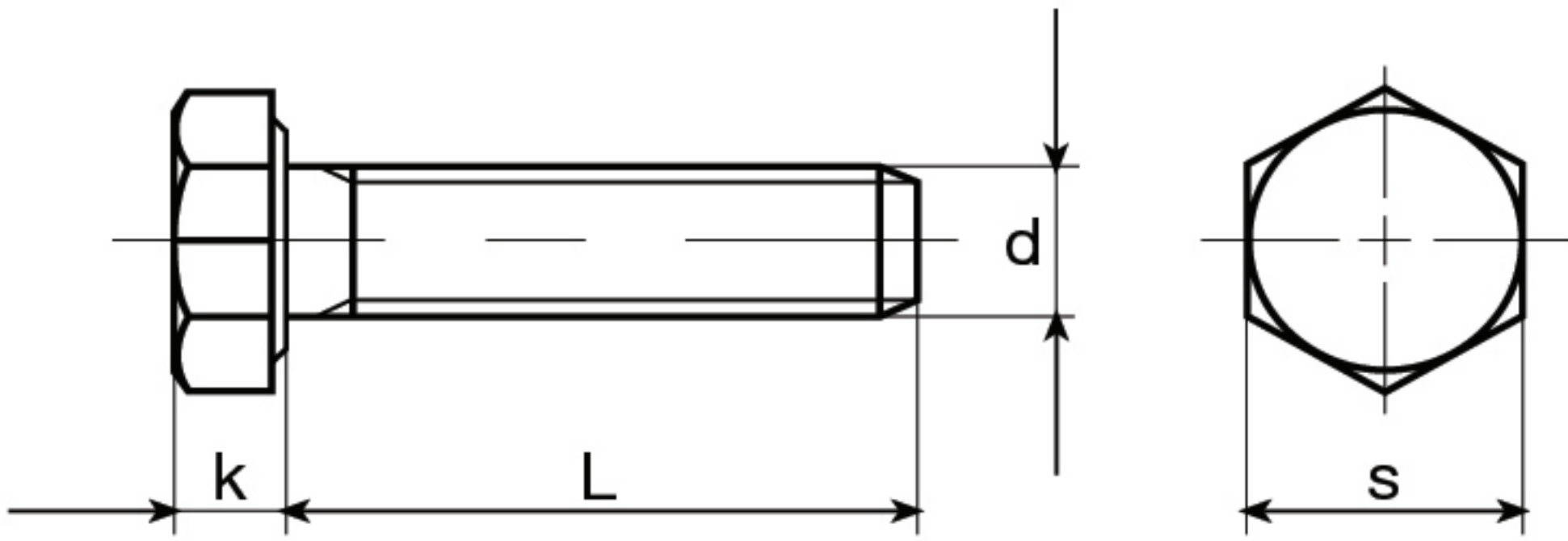

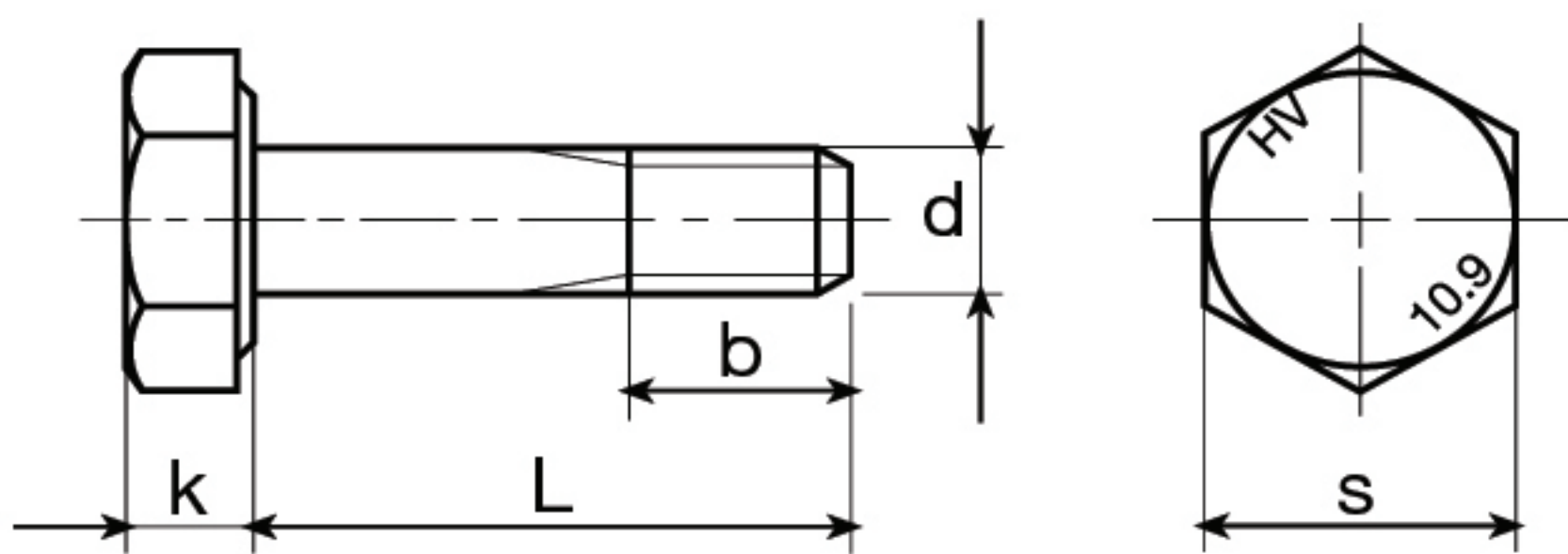
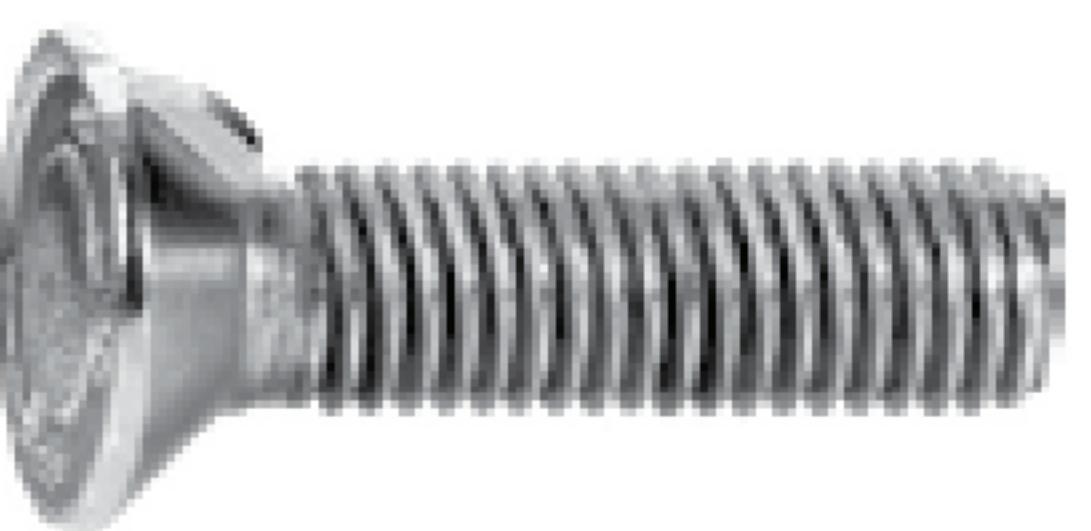
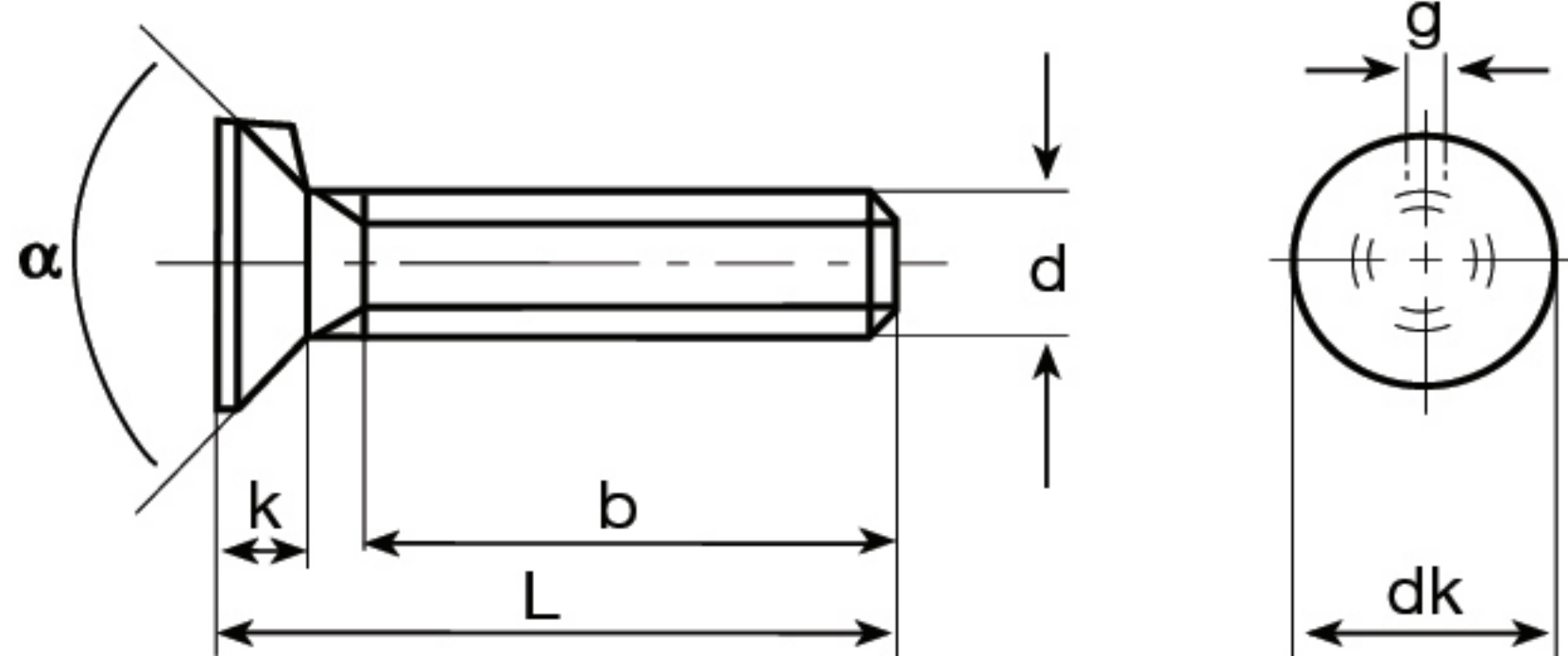

MARTIN 

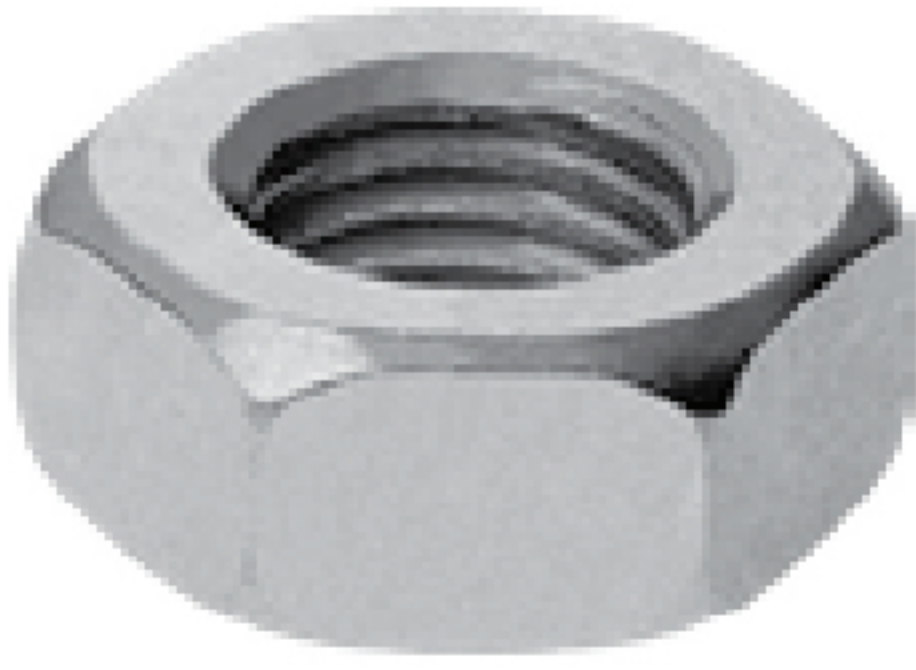
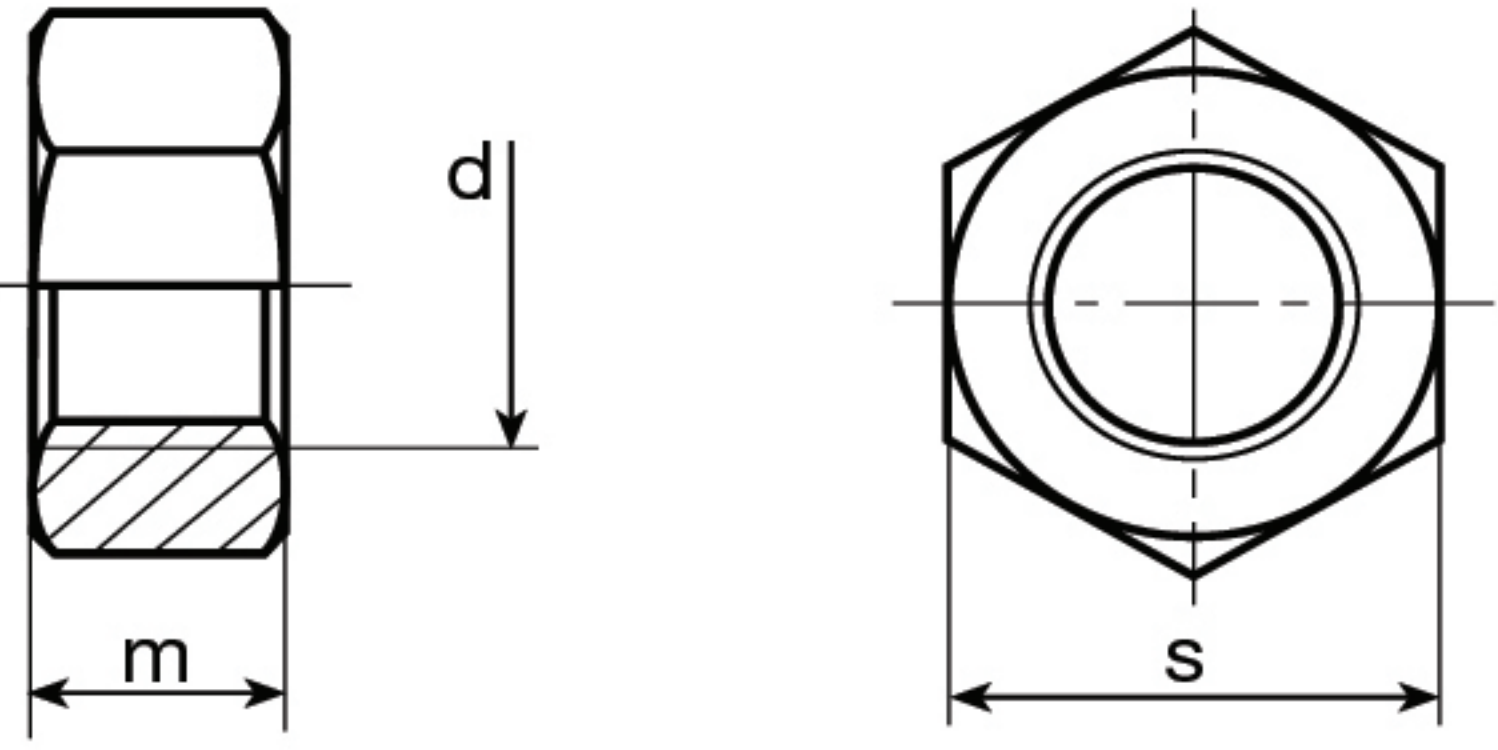
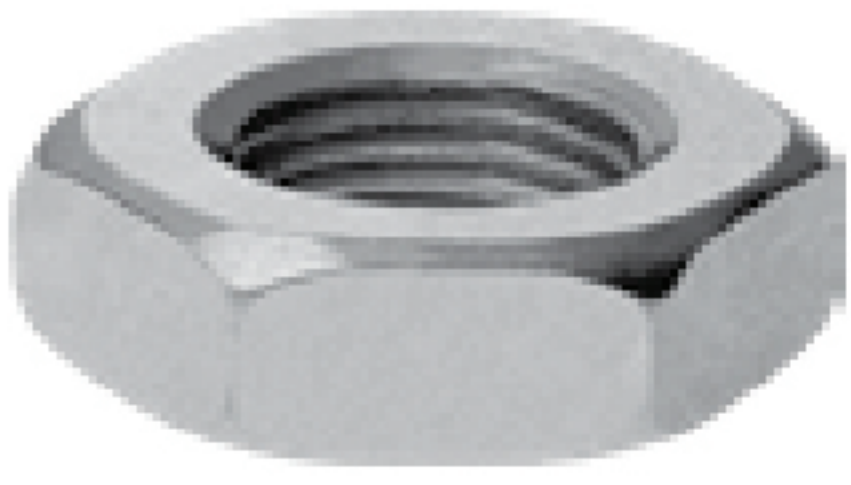
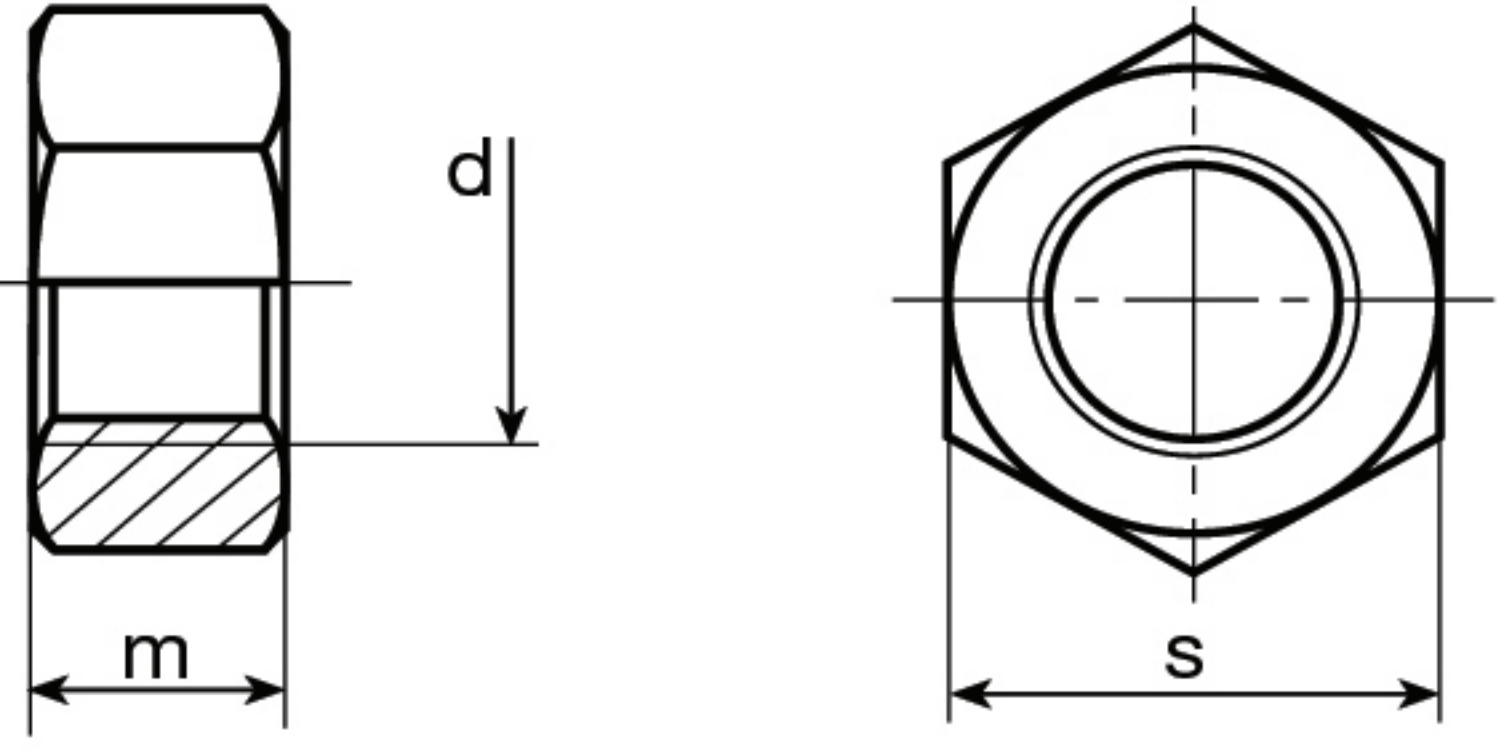
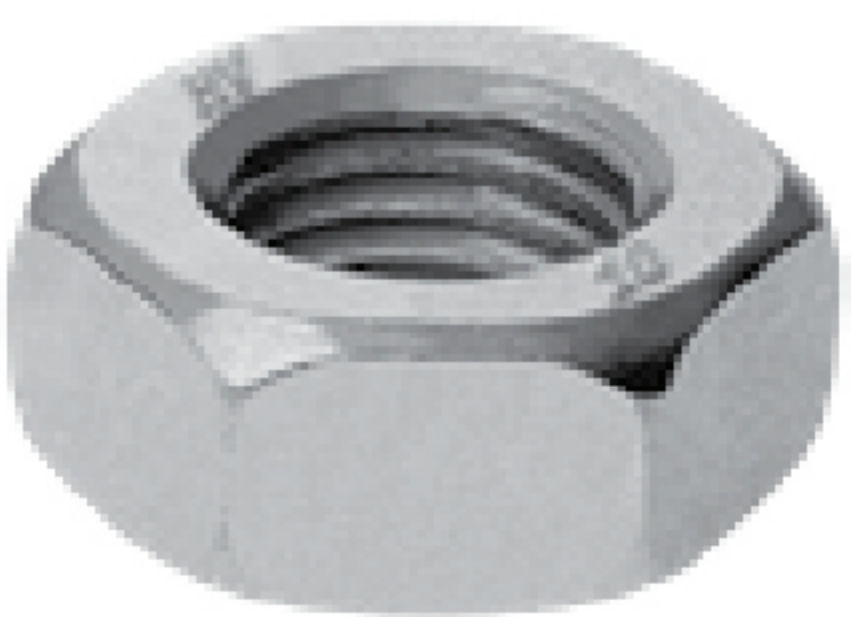
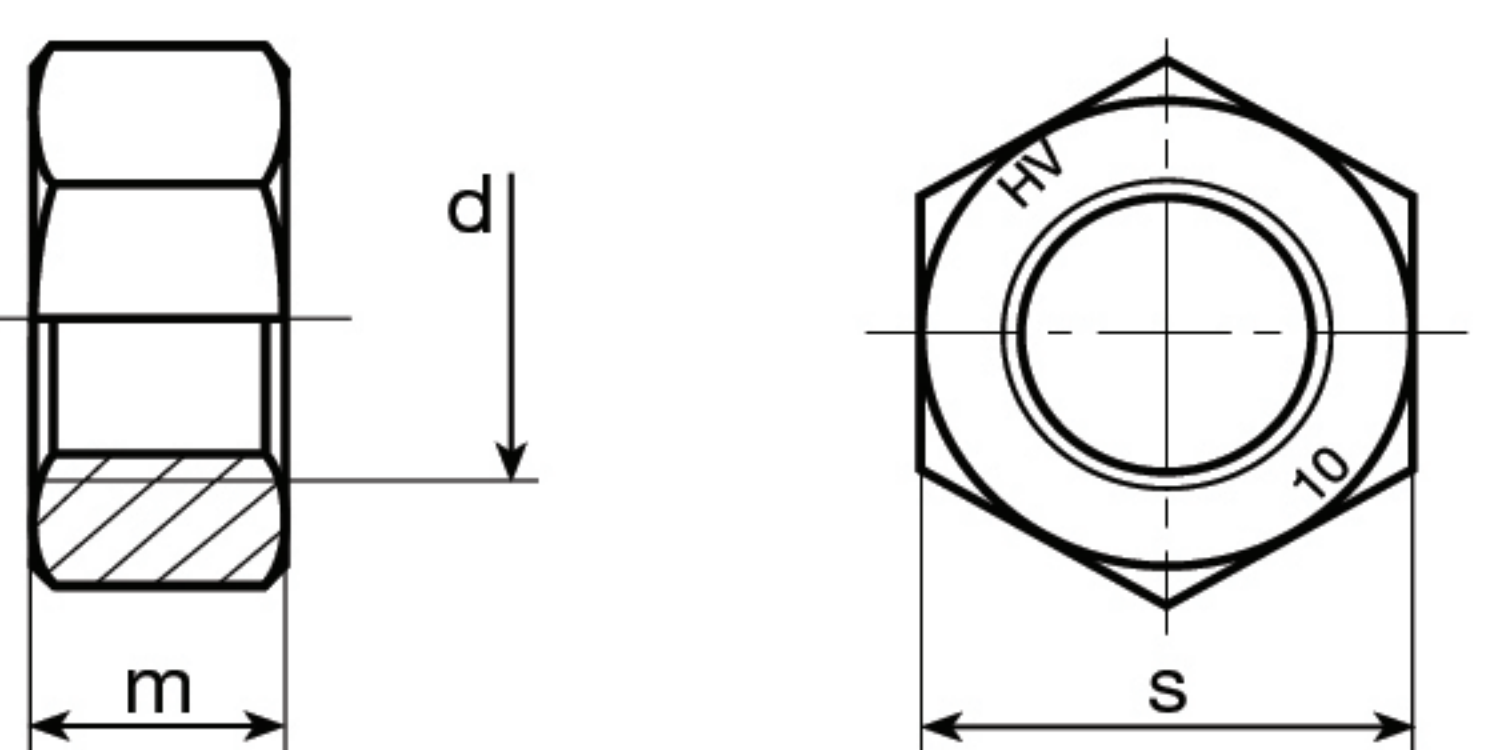
	Size	Grade	Finish Available	Standard Din	ISO
<p>Socket Head Cap Screws</p> 	M5 to M20	8.8, 10.9, 12.9	Black, Zinc, HDG	912	4762
					
<p>Socket Countersunk Head Screws</p> 	M5 to M20	8.8, 10.9	Black, ZINC, HDG	7991	
					
<p>Socket Button Head Screws</p> 	M5 to M12	8.8, 10.9	Black, ZINC	7380	7380
					
<p>Flange Socket Head Cap Screws</p> 	M5 to M12	8.8, 10.9, 12.9	Black, ZINC		
					
<p>Flange Bolts</p> 	M5 to M16	8.8, 10.9, 12.9	Black, ZINC, HDG	6921	8100
					
<p>Flange Bolts with Serration</p> 	M5 to M16	8.8, 10.9, 12.9	Black, ZINC, HDG	6921	8100
					

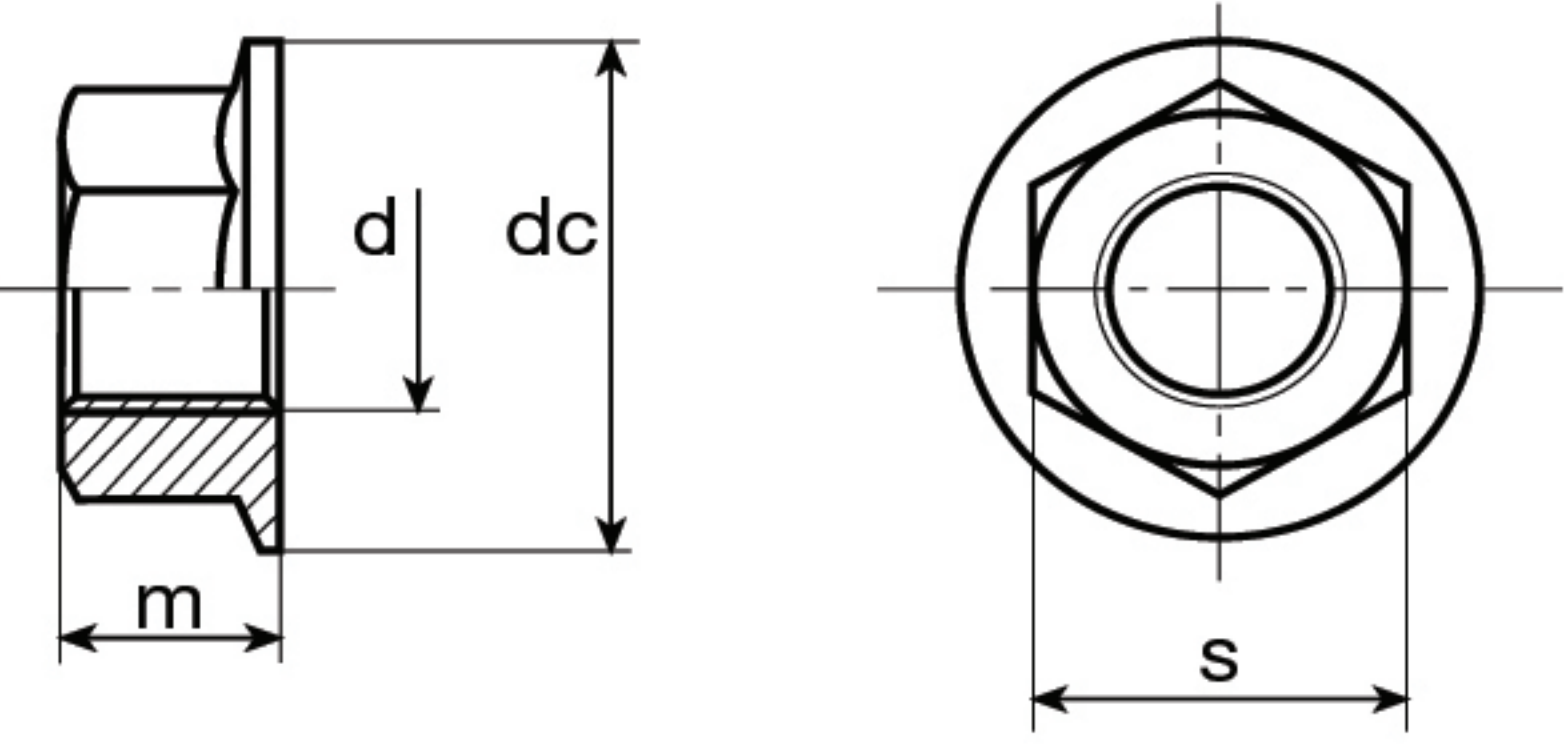
	Size	Grade	Finish Available	Standard	
				Din	ISO
<p>Mushroom Head Square Neck Bolts</p> 	M6 to M20	4.8, 8.8	Black, ZINC, HDG	603	8677
					
<p>Hex Head Bolts Partial Thread</p> 	M5 to M30	4.6, 4.8, 5.6, 5.8, 8.8, 10.9, 12.9	Black, ZINC, HDG	931	4014
					
<p>Hex Head Bolts Full Thread</p> 	M5 to M30	4.6, 4.8, 5.6, 5.8, 8.8, 10.9, 12.9	Black, ZINC, HDG	933	4017
					
<p>High Strength Structural Bolts</p> 	M12 to M20	8.8, 10.9	Black, ZINC, HDG	1614	7412
					
<p>Flat Countersunk Nib Bolts</p> 	M6 to M20	8.8, 10.9	Black, ZINC, HDG	614	
					

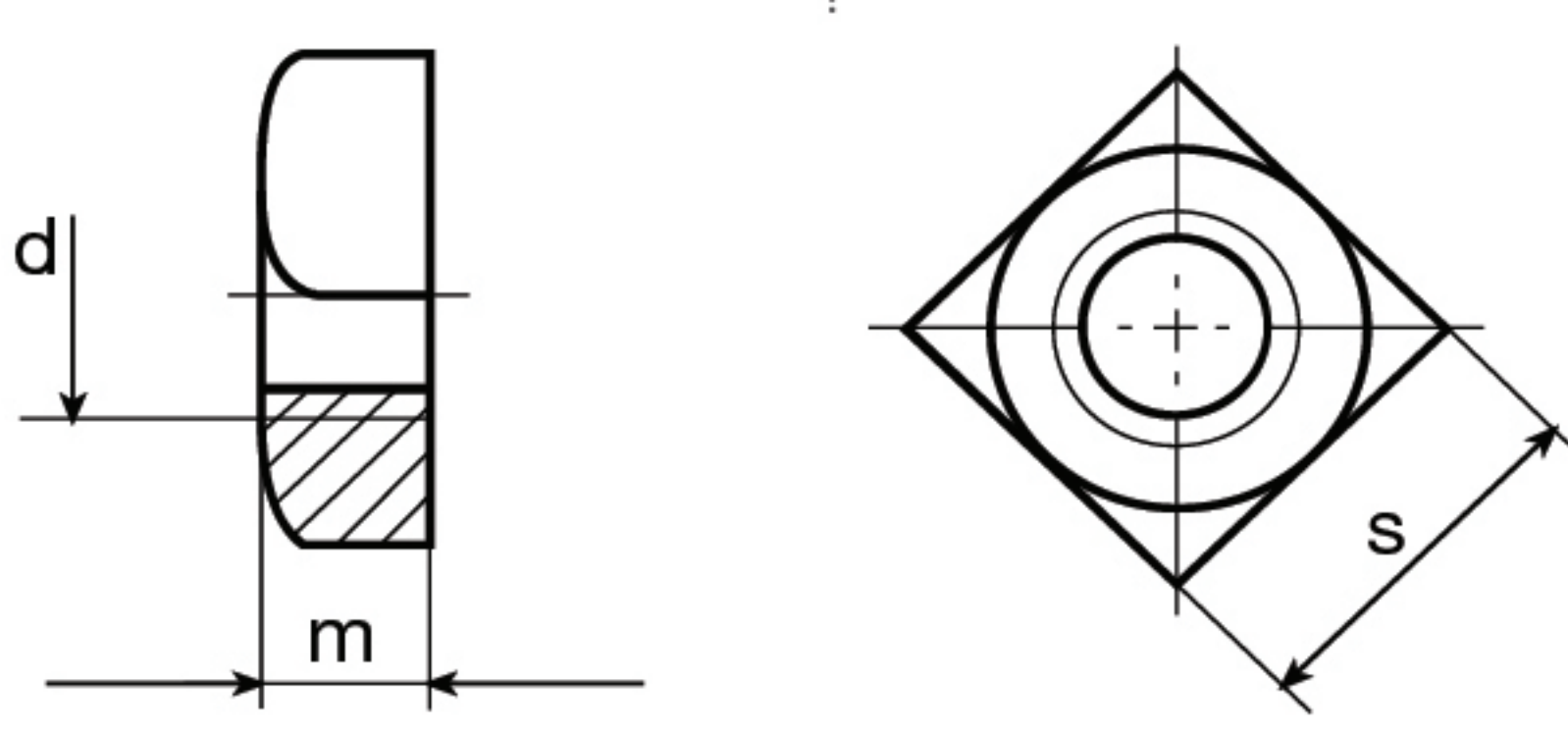

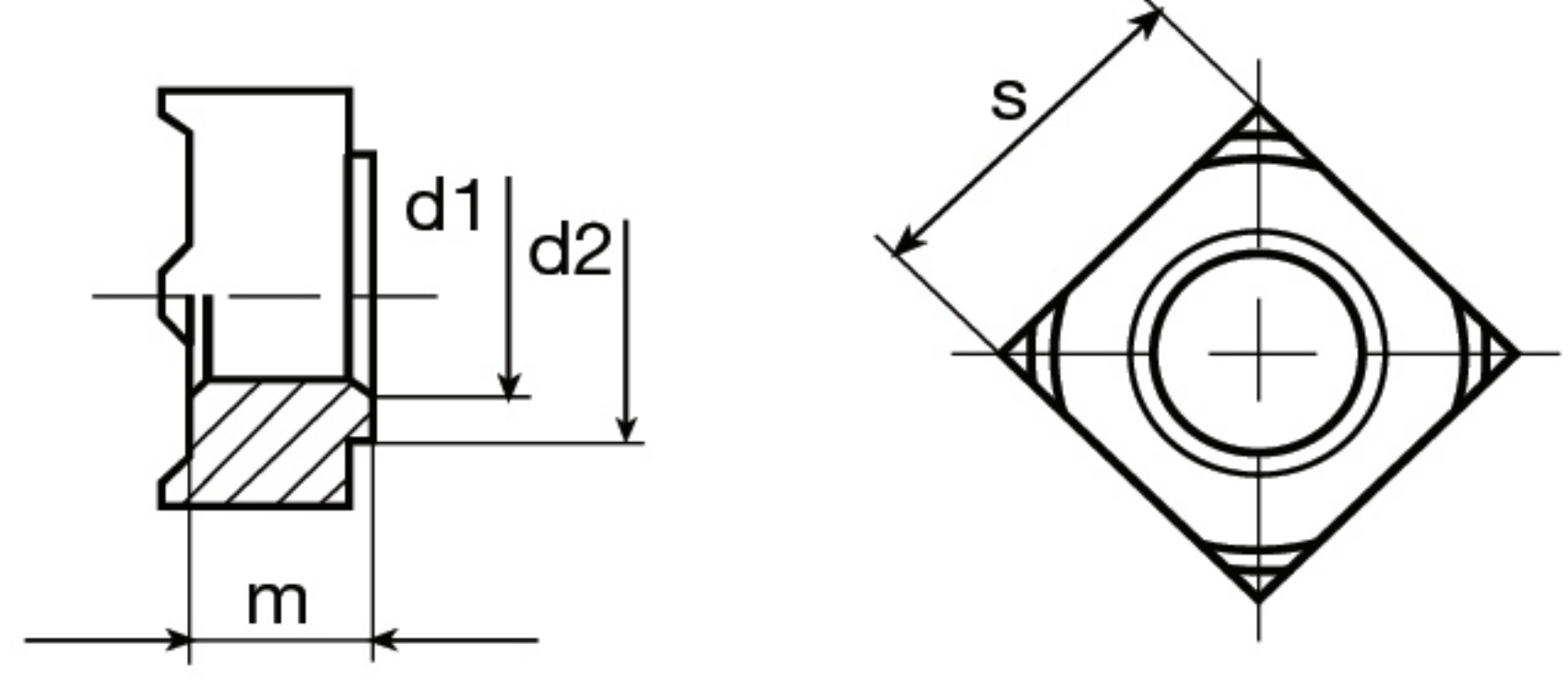
	Size	Grade	Finish Available	Standard Din	ISO
<p>Hex Nuts</p> 	M5 to M30	4, 6, 8, 10	Black, Zinc, HDG	934	4032
					
<p>Thin Hex Nuts / Lock Nuts</p> 	M8 to M30	8, 10	Black, ZINC, HDG	936	
					
<p>High Strength Structural Hex Nuts</p> 	M12 to M30	8, 10	Black, Zinc, HDG	6915	7414
					
<p>Flange Nuts with Serration</p> 	M6 to M20	8, 10	Black, Zinc, HDG	6923	4161
					
<p>Square Nut</p> 	M6 to M12	8, 10	Black, Zinc, HDG	557	
					
<p>Square Weld Nut</p> 	M6 to M12	8, 10	Black, ZINC, HDG	928	
					

	Size	Grade	Finish Available	Standard	
				Din	ISO
Plain Washers	M5 to M30		Black, Zinc, HDG	125-A	7089

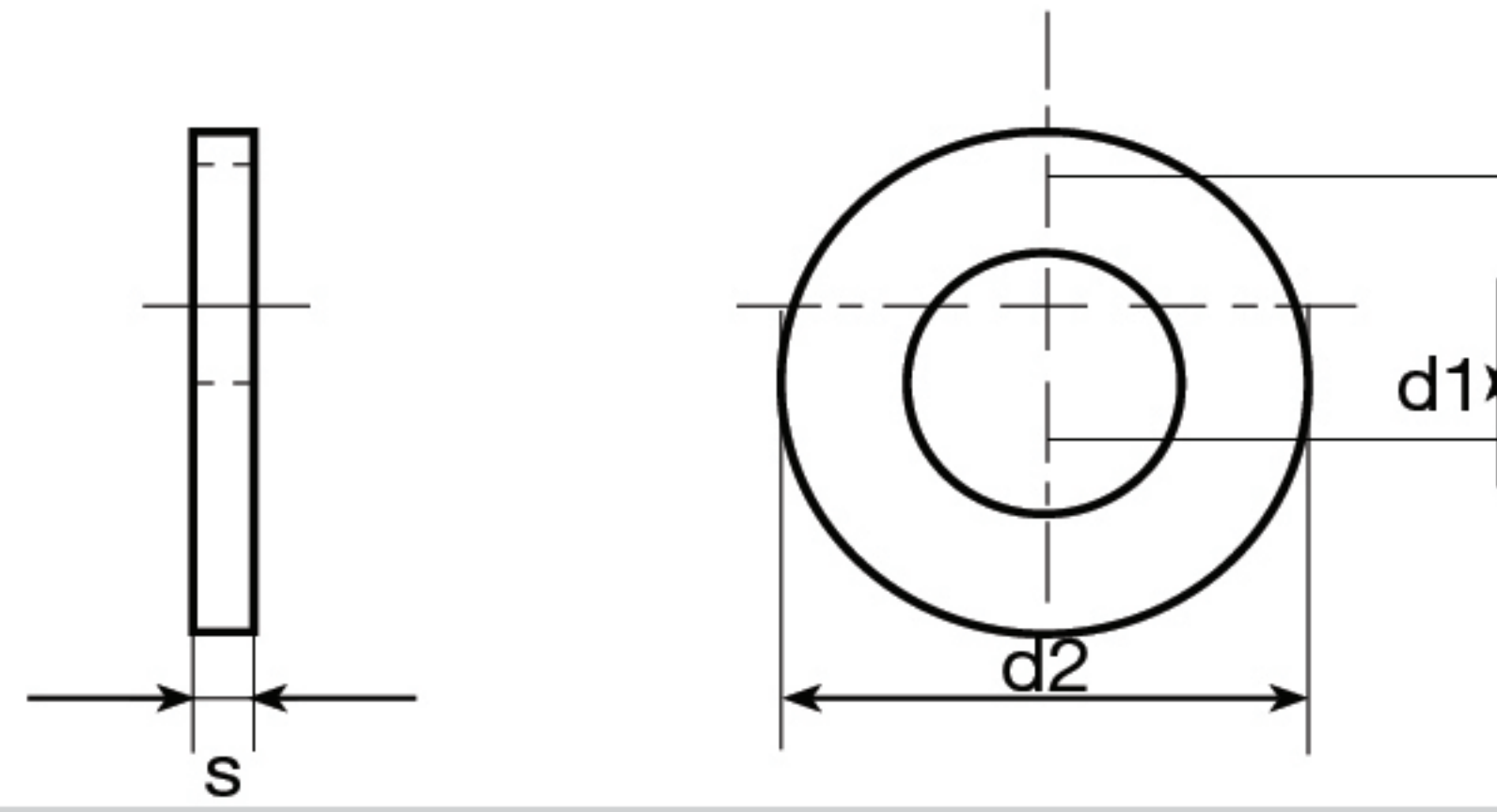

Spring Lock Washers

M5 to M30

Black, ZINC, HDG

127-B

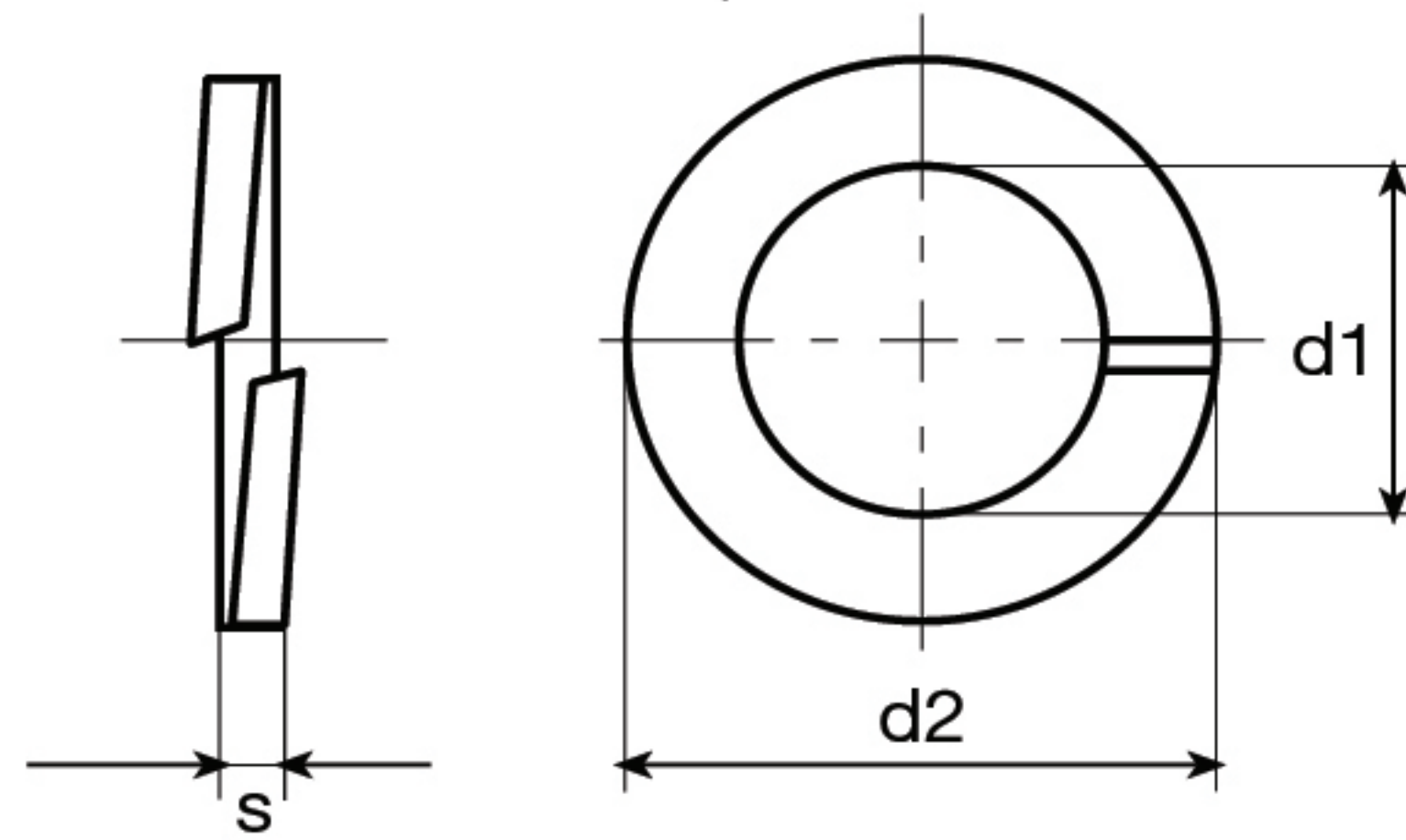

High Strength Structural Washers

M12 to M30

Black, Zinc, HDG

6916

7416

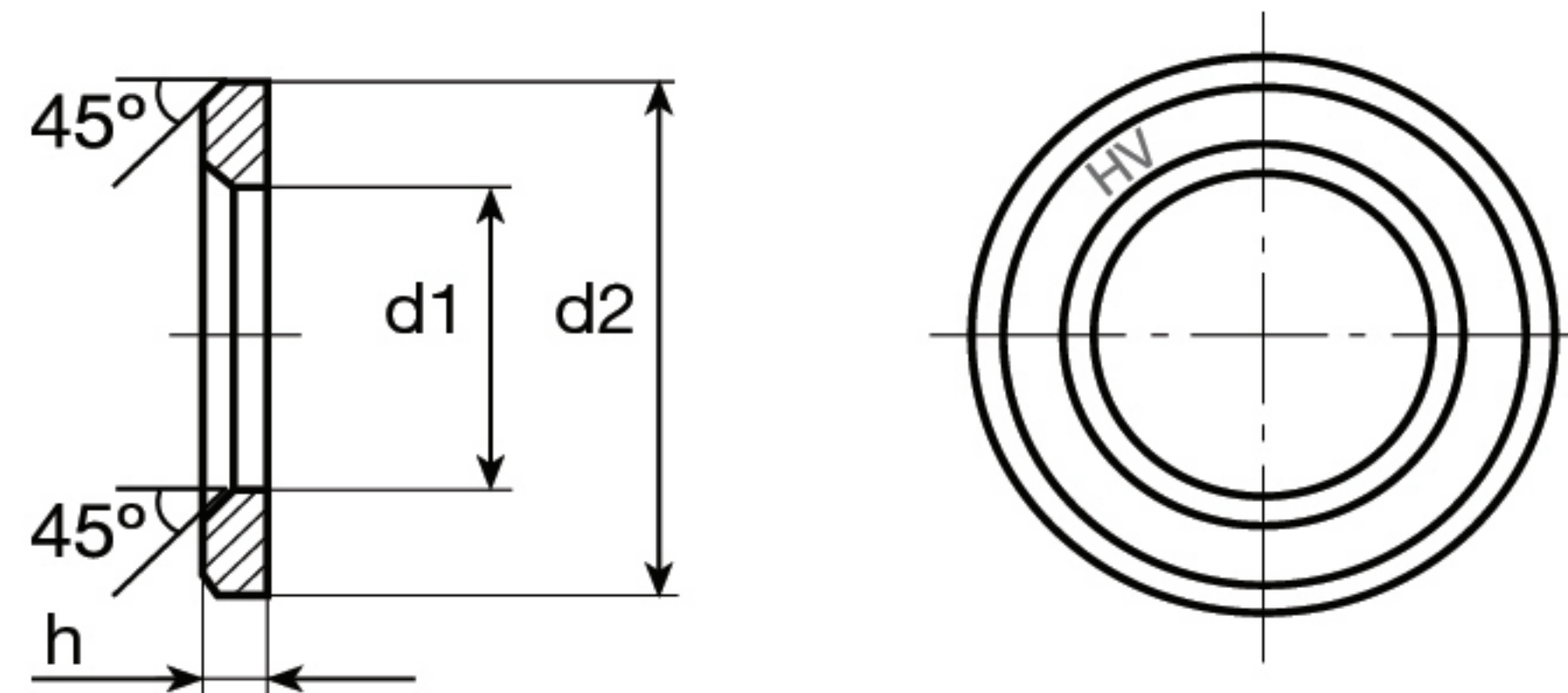

Washers (DIN 9021)

M3 to M24

Black, Zinc, HDG

9021

7093

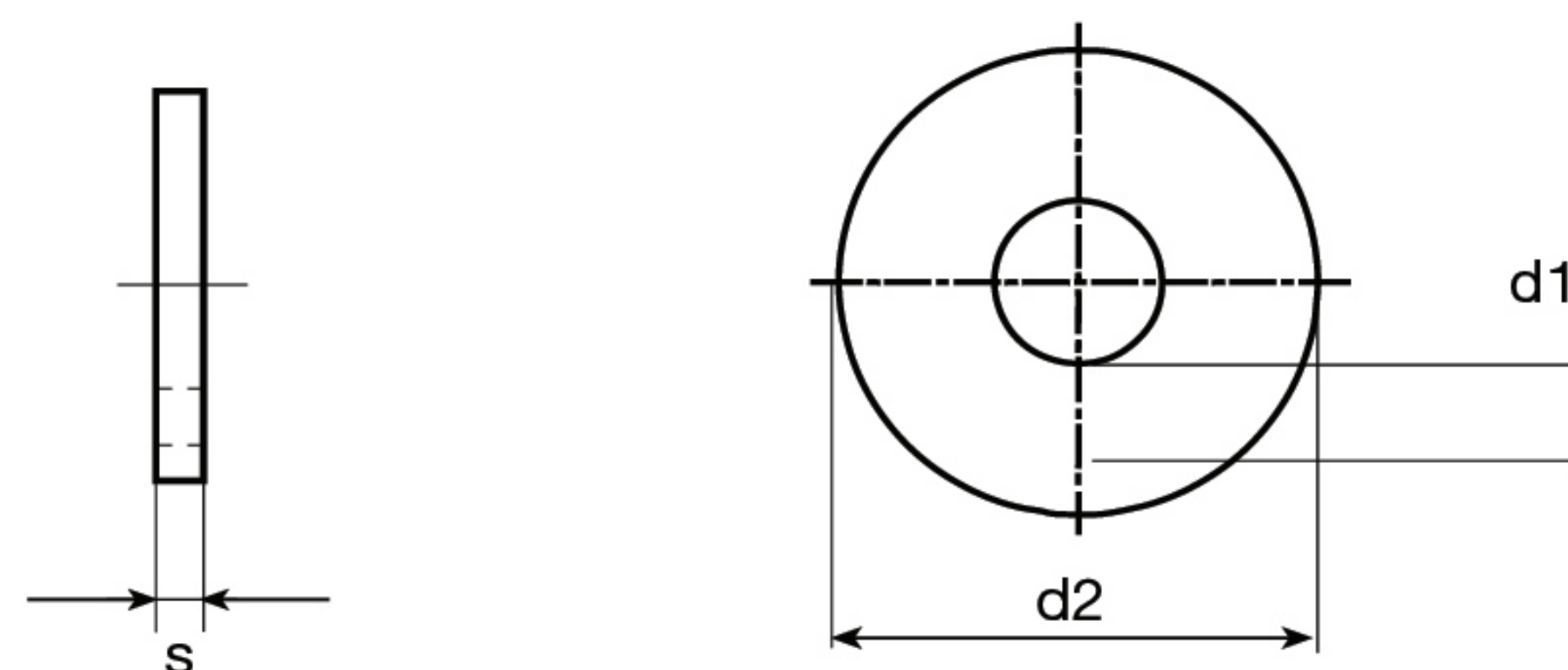

Specifications & Strength Ratings

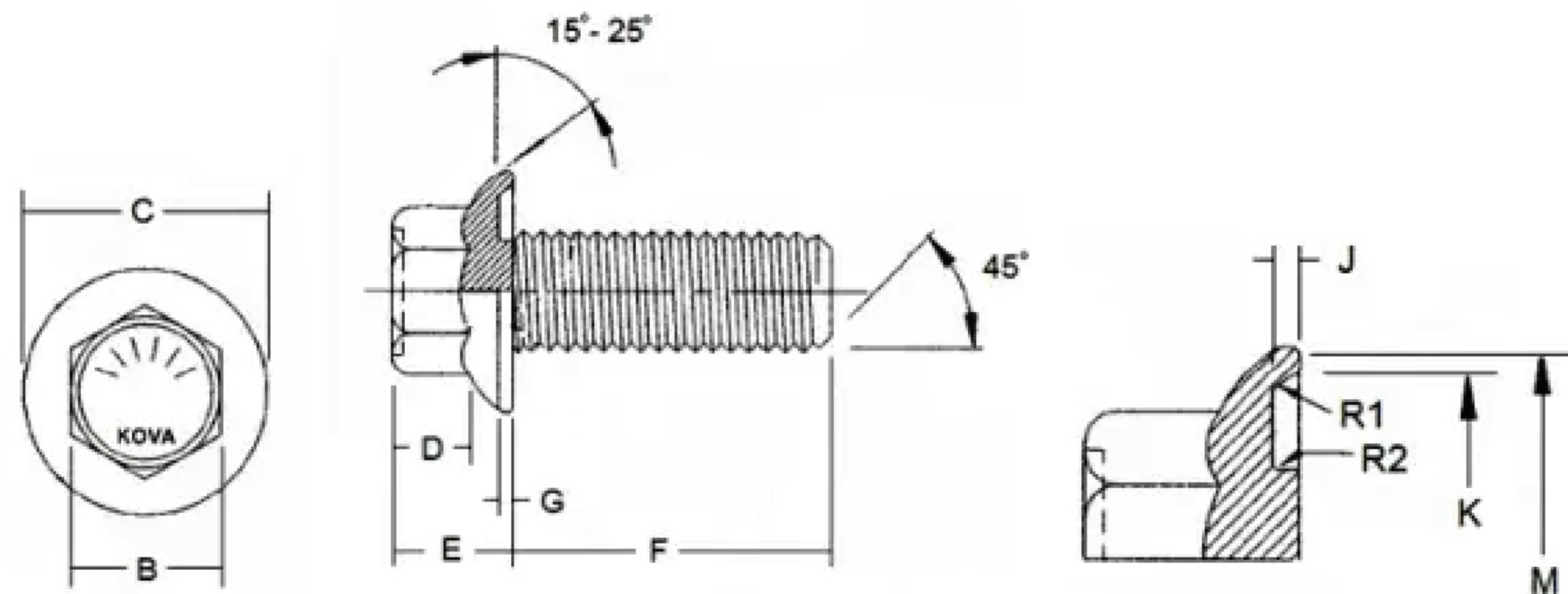

Size	B		C		D		E		F		G		J		K		M	
	Max	Min	Max	Min	Max	Min	Max	Min	Max	Min	Max	Min	Max	Min	Max	Min	Min	
5/16-18 x 3/4	.500	.489	.730	.210	.319	.303	.750	.720	.083	.062	.050	.040	.605	.560	.610			
5/16-18 x 1	.500	.489	.730	.210	.319	.303	1.00	.970	.083	.062	.050	.040	.605	.560	.610			
5/16-18 x 1-1/4	.500	.489	.730	.210	.319	.303	1.25	1.21	.083	.062	.050	.040	.605	.560	.610			
5/16-18 x 1-1/2	.500	.489	.730	.210	.319	.303	1.50	1.46	.083	.062	.050	.040	.605	.560	.610			
3/8-16 x 1	.500	.550	.807	.256	.380	.365	1.00	.970	.095	.071	.050	.040	.675	.655	.709			
3/8-16 x 1-1/4	.500	.550	.807	.256	.380	.365	1.25	1.21	.095	.071	.050	.040	.675	.655	.709			
3/8-16 x 1-1/2	.500	.550	.807	.256	.380	.365	1.50	1.46	.095	.071	.050	.040	.675	.655	.709			
7/16-14 x 1	.500	.612	.950	.300	.440	.410	1.00	.970	.099	.075	.050	.040	.805	.768	.866			
7/16-14 x 1-1/2	.500	.612	.950	.300	.440	.410	1.50	1.44	.099	.075	.050	.040	.805	.768	.866			
5/16-18 x 2	.500	.612	.950	.300	.440	.410	2.00	1.94	.099	.075	.050	.040	.805	.768	.866			

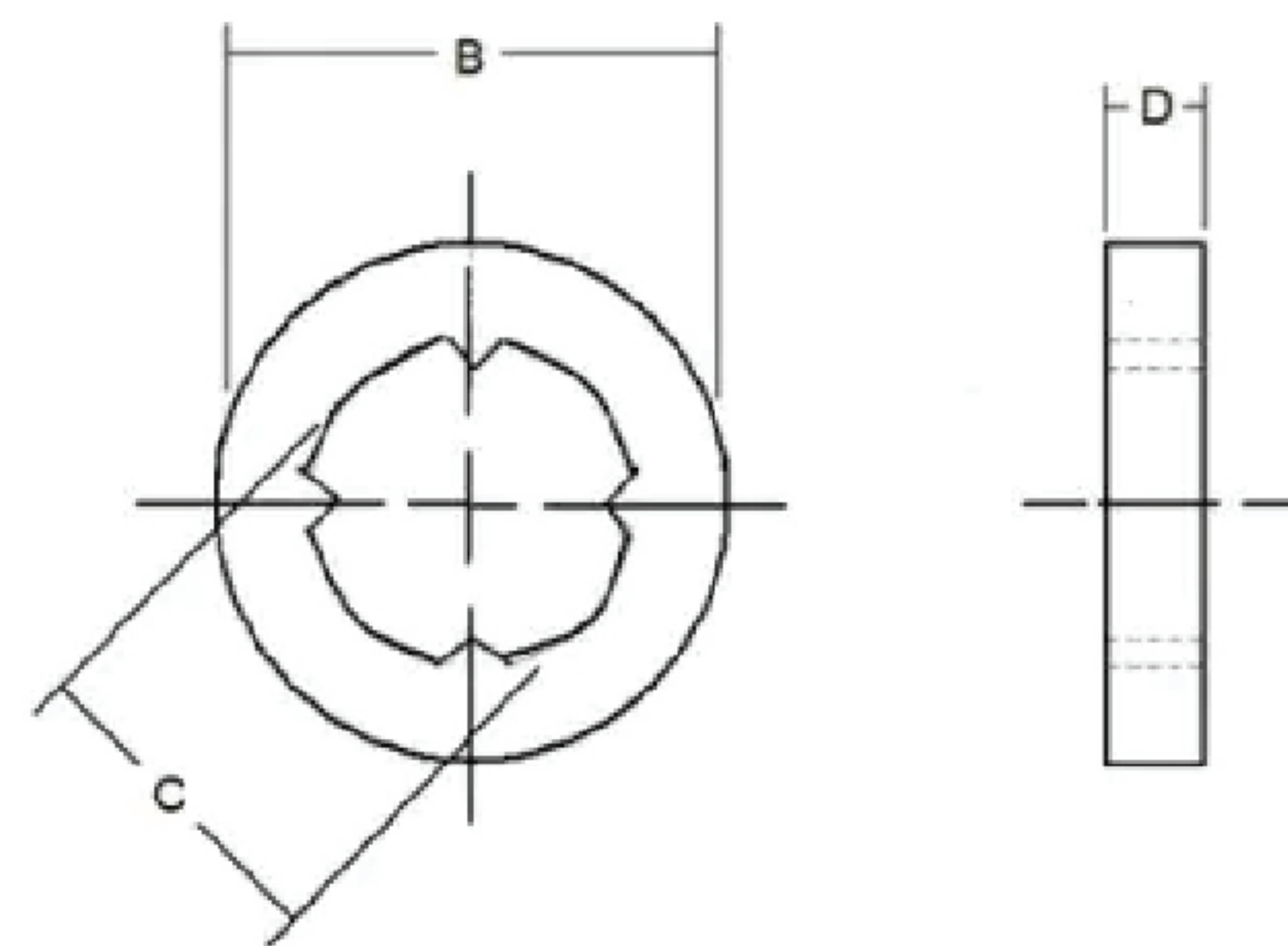

Size	B		C		D	
	Max	Min	Max	Min	Max	Min
5/16	.567	.551	Ref 0.350		.115	.090
3/8	.646	.630	.420	.400	.120	.105
7/16	.736	.720	.510	.490	.130	.120

MARTIN



Fastening Solutions

Class "C" Components,
Part-to-Print Components
& Fasteners

Engineering Support

Kitting & Sub-Assembly Services

Vendor Managed Inventory

To learn more about our Fastening Solutions,
scan the QR code or contact your Martin
Sales Rep today!

800.828.8116
martinsupply.com